

Schéma 4-01-02 : Traction – Signal S14 – Zone 12

Schéma 4-01-01 : Traction – Signal C1 – Zone 37

Schéma 4-02-08 : Traction – Branchements 10 – 12 – TJD 9

Schéma 4-02-06 : Traction – Signal C17 – Zone 9

Traction

Schéma 3-01-09 : Moteur – TJD 9

Schéma 3-01-09 : Moteur – TJD 9

Moteurs

Schéma 3-01-11 : Moteur – Branchement 11

Schéma 2-02-12 : Signal S14

Schéma 2-01-01 : Signal C1

Signaux

Schéma 2-01-12 : Signal C17

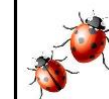

Ladybird – Réseau BOB-TEE 91

Plaque de raccordement Module 7 : PR-M7-1

09/11/2022

Feuille : 0-04-07

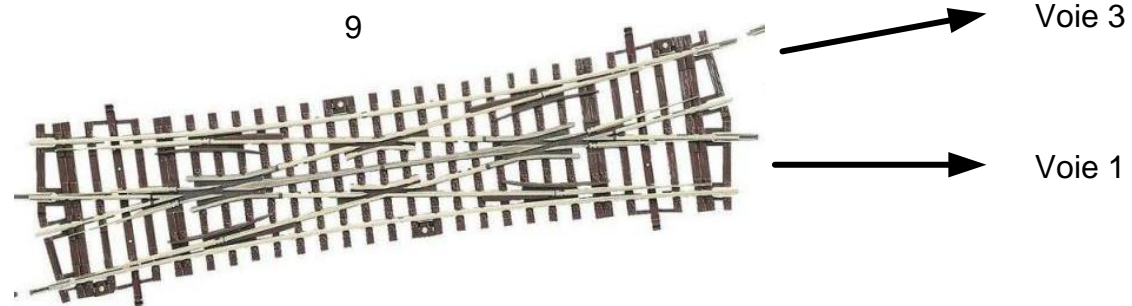

Voir principes de raccordement des moteurs MP1

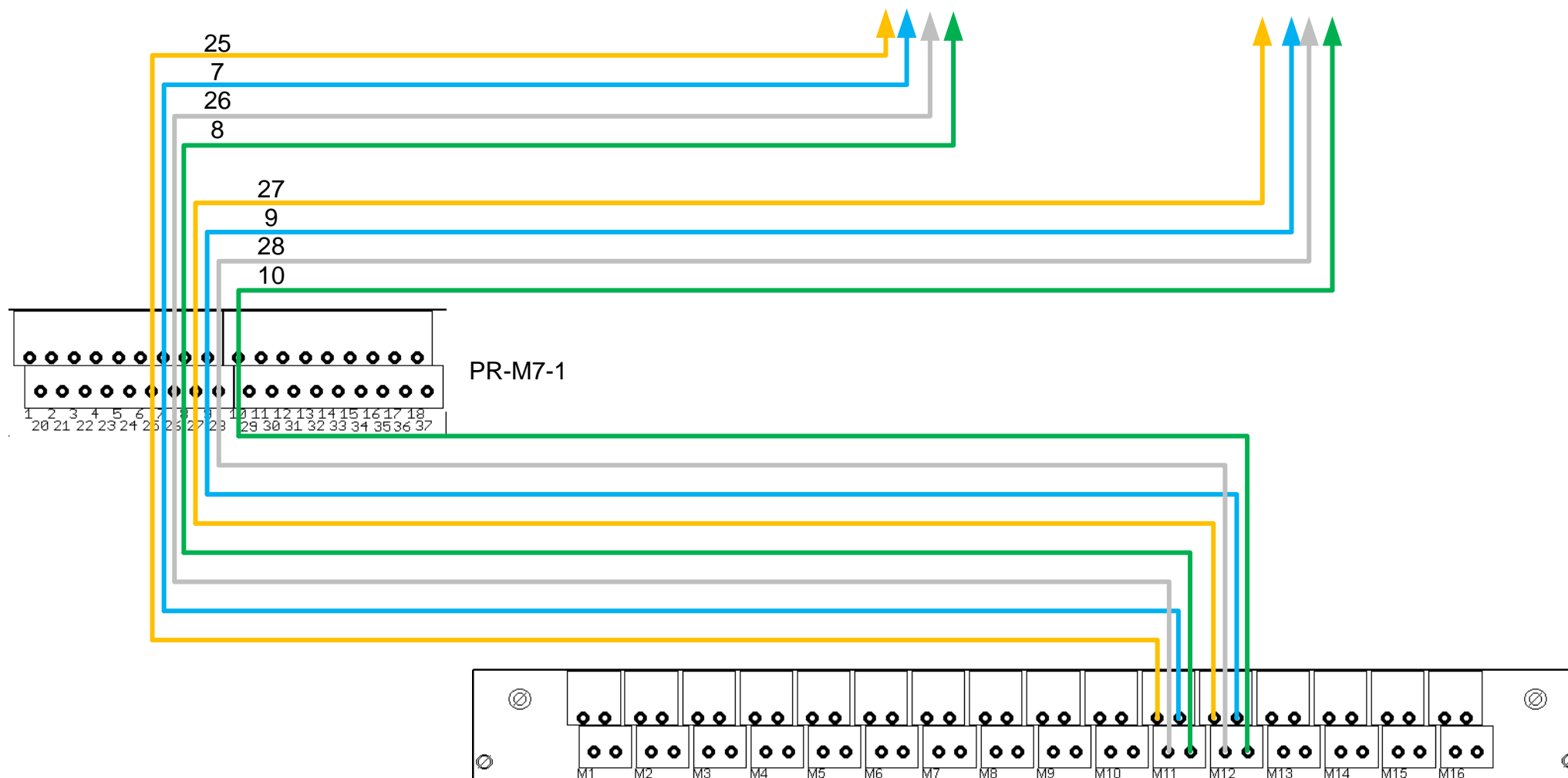

Ladybird – Réseau BOB-TEE 91

TJS 9

09/11/2022

Feuille : 3-01-09

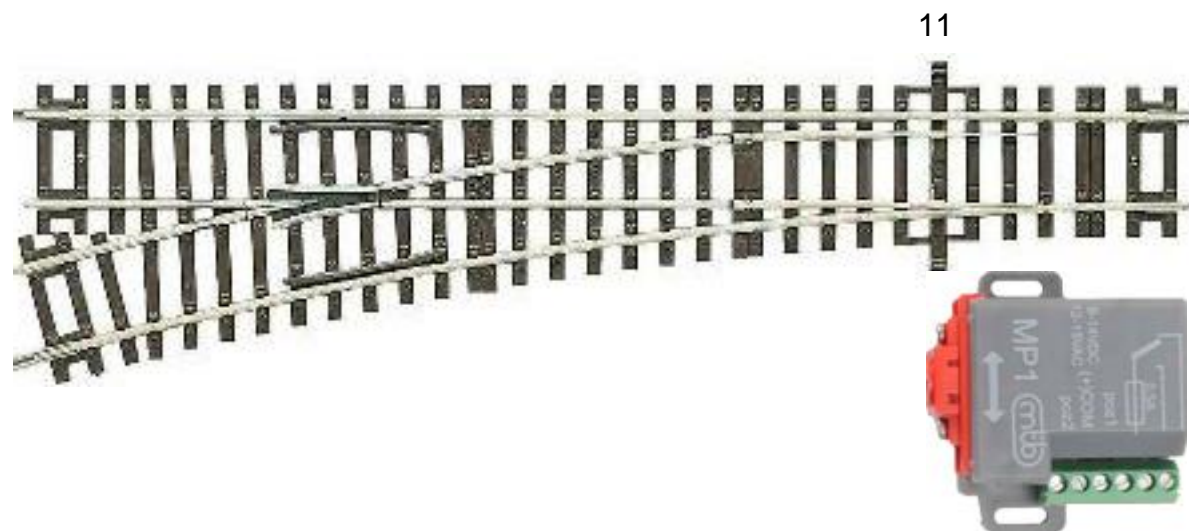

Voir principes de raccordement des moteurs MP1

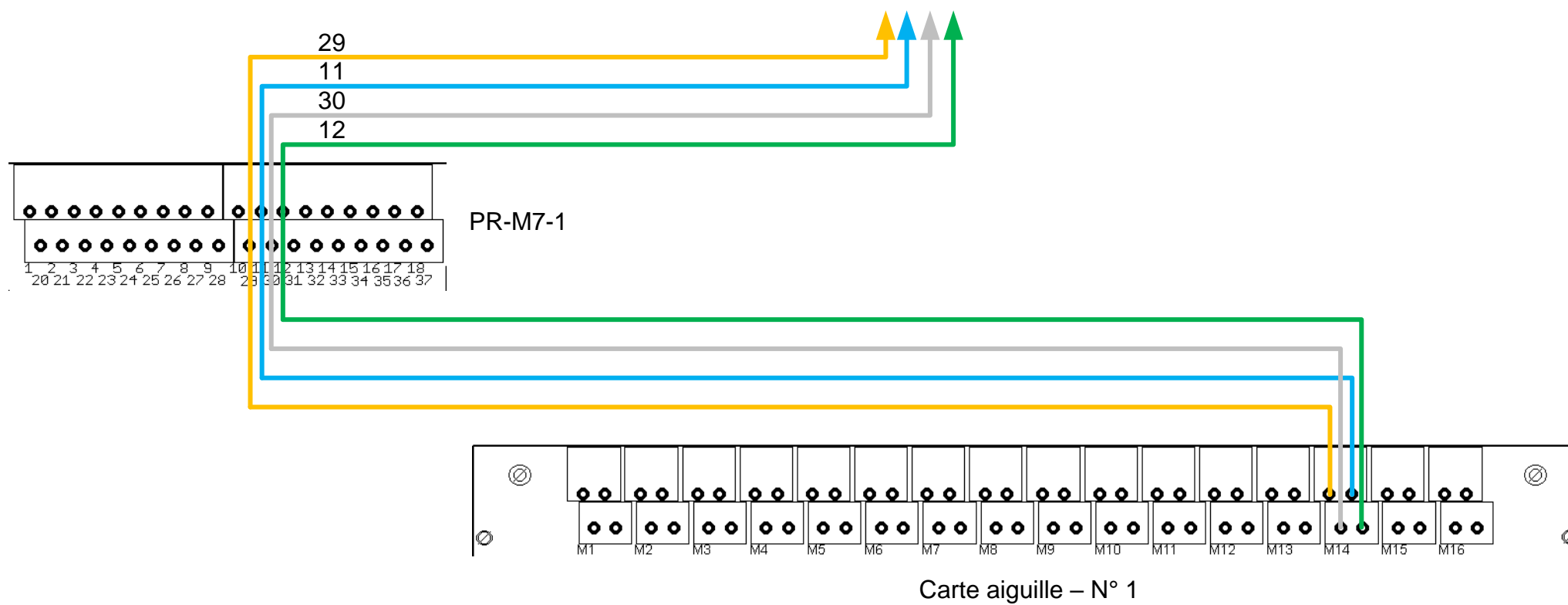

Ladybird – Réseau BOB-TEE 91

Branchement 11

09/11/2022

Feuille : 3-01-11

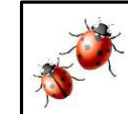
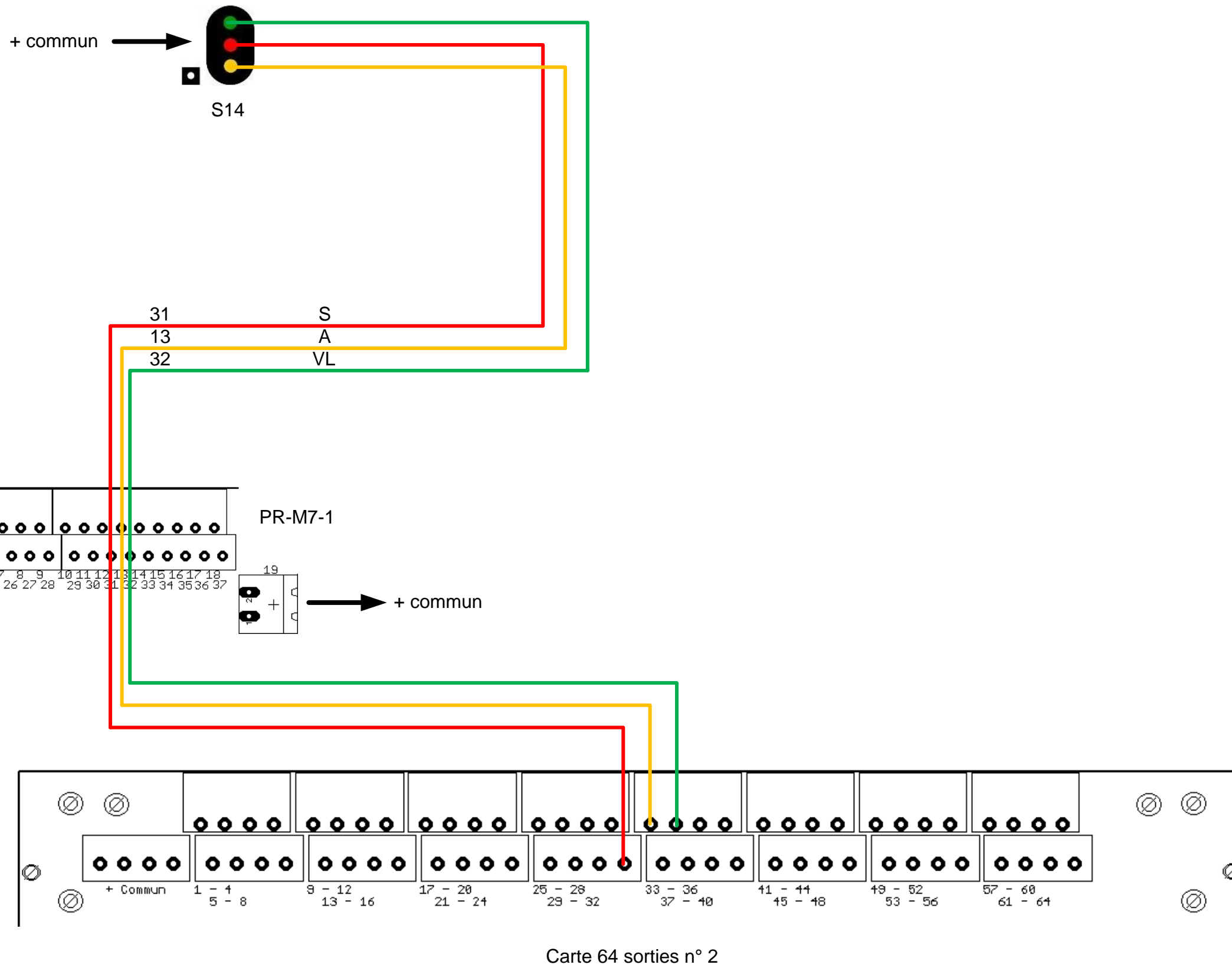

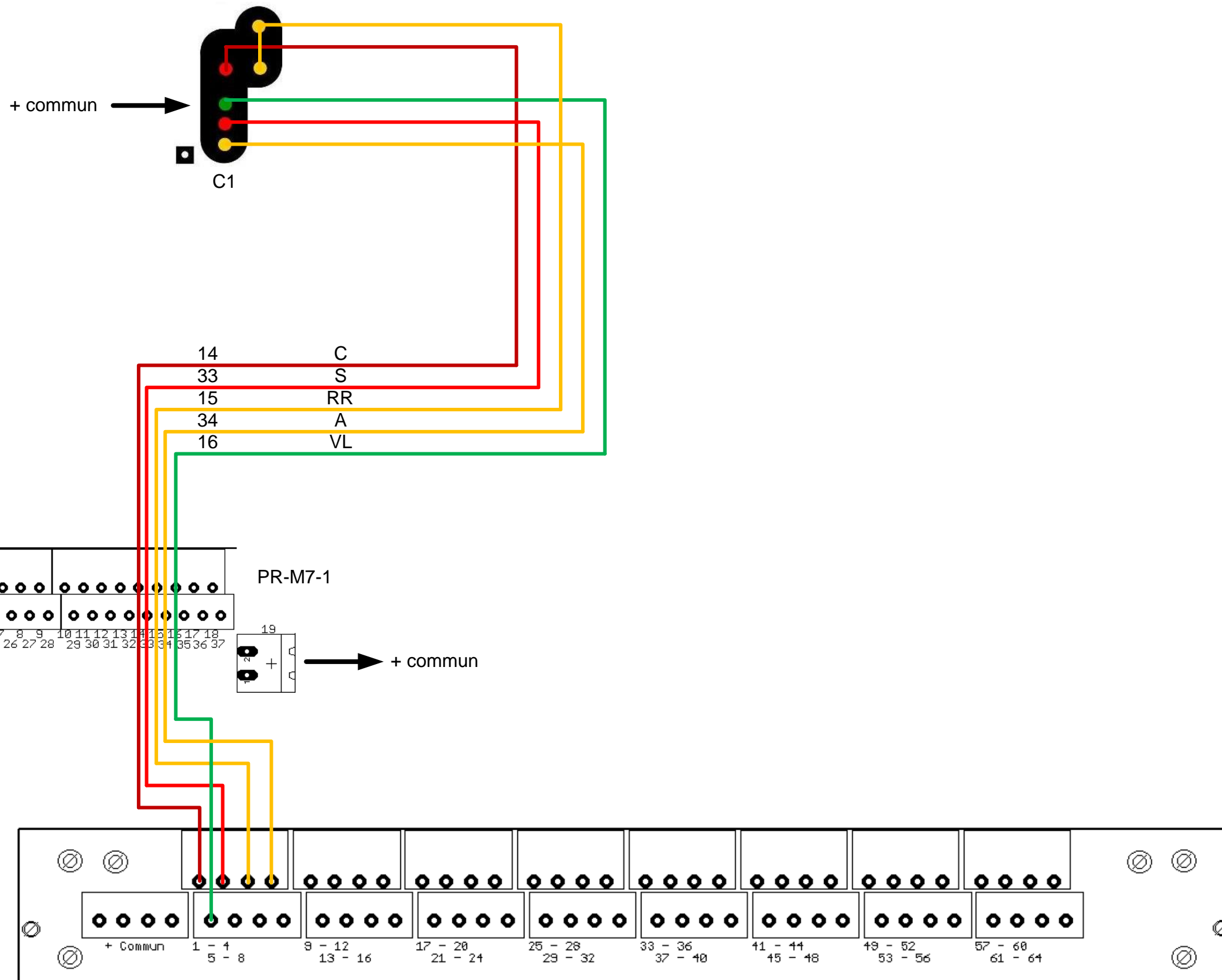

Carte 64 sorties n° 1



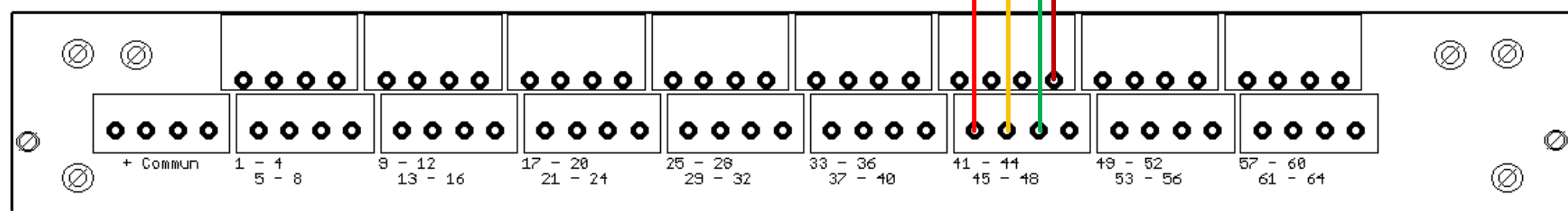
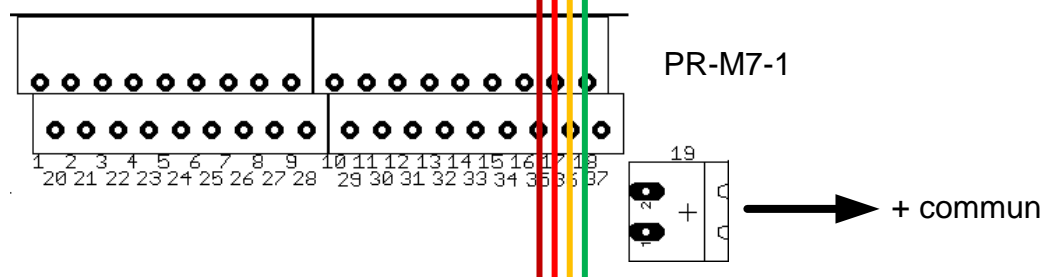
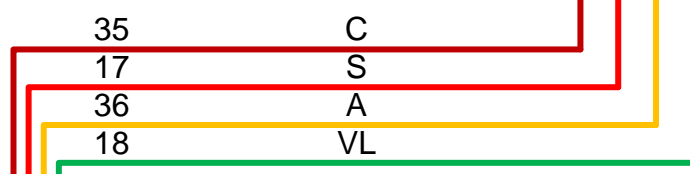
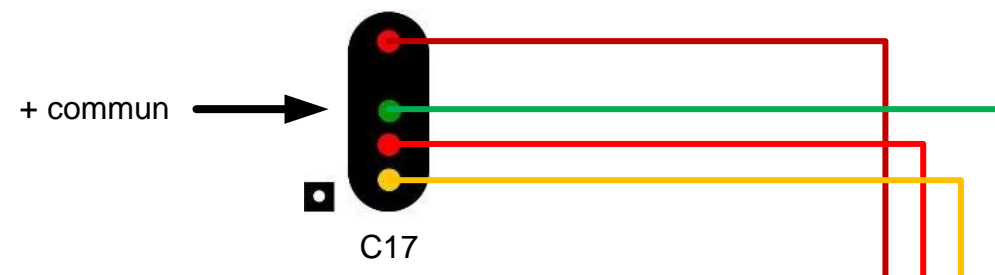

	Ladybird – Réseau BOB-TEE 91
Signal C17	
09/11/2022	
Feuille : 2-01-12	